

TESTATA 99/1200W 250V (KERR-AUS)		REF. 2664 KERRICK	
POS	REF.	DESCRIZIONE	N°
1	117 AUS	CAVO ELETTRICO 2X1 MT.8,5 AUS	1
2	138	PASSACAVO	1
3	139	BLOCCACAVO	1
4	1006	VITE PFU TMT PHL 5X20 ZINC. P/R	2
5	3464	MORSETT. 300/500 EU/NEVRAD	1
6	2589	GANCIO 99 POR TACAVO	1
7	1026	VITE PAT TMT PHL 5X30 ZINC.	4
8	2588	MANIGLIA 99	1
9	1050	VITE PAT TMT PHL 5X35 ZINC.	2
10	1050	VITE PAT TMT PHL 5X35 ZINC.	2
11	2590	COPERCHIO 99	1
12	326	INTERUTTORE ANTISPRUZZO	1
13	1006	VITE PFU TMT PHL 5X20 ZINC. P/R	4
14	3937	FILTRO MTP/65 Ø 95	1
15	1050	VITE PAT TMT PHL 5X35 ZINC.	6
16	2738-1	COPERTURA 99 S/FORI	1
17	3969	RONDELLA H=8 Ø 85 X65	1
18	3900	FILTRO MTP/65 Ø160-120 H=88	1
19	2627	VITE PAT TMT PHL 5X40 ZINC.	6
20	1006	VITE PFU TMT PHL 5X20 ZINC. P/R	4
21	2591-1	FERMAMOTORE 99	1
22	3901	GUARNIZIONE A L S/F H=5,5	1
23	3975	MOT. BD382 1200W 240-250 50/60	1
24	3901	GUARNIZIONE A L S/F H=5,5	1
25	3866	RONDELLA MTP/65 MM18 Ø230-145	1
26	1189 G	BASAMENTO 500 C/GUARN.	1
*	7632/PI	KIT ELE TTR. 40CM MOTORE POKE-IN	1

KIT FILTRANTE 500 CONICO SAN.COMPL.		REF. 3247 SAN	
POS	REF.	DESCRIZIONE	N°
1	3706	BUSSOLA D.8 PLAST.	4
2	3724	VITE PAT TMT PHL 5X25 INOX	4
3	2823-1	CORPO ANTISCHIUMA 99 ALTO	1
4	3138	FILTRO RETE 0,3 D.90 H=45	1
5	2676	GALLEGGIANTE 99 ALTO	1
6	507	ANELLO PORTAFILTRO SERIE 500	1
7	2860 SAN	FILTRO POLYESTERE 300 CONICO SAN.	1
8	2859	CESTELLO 300 CONICO	1

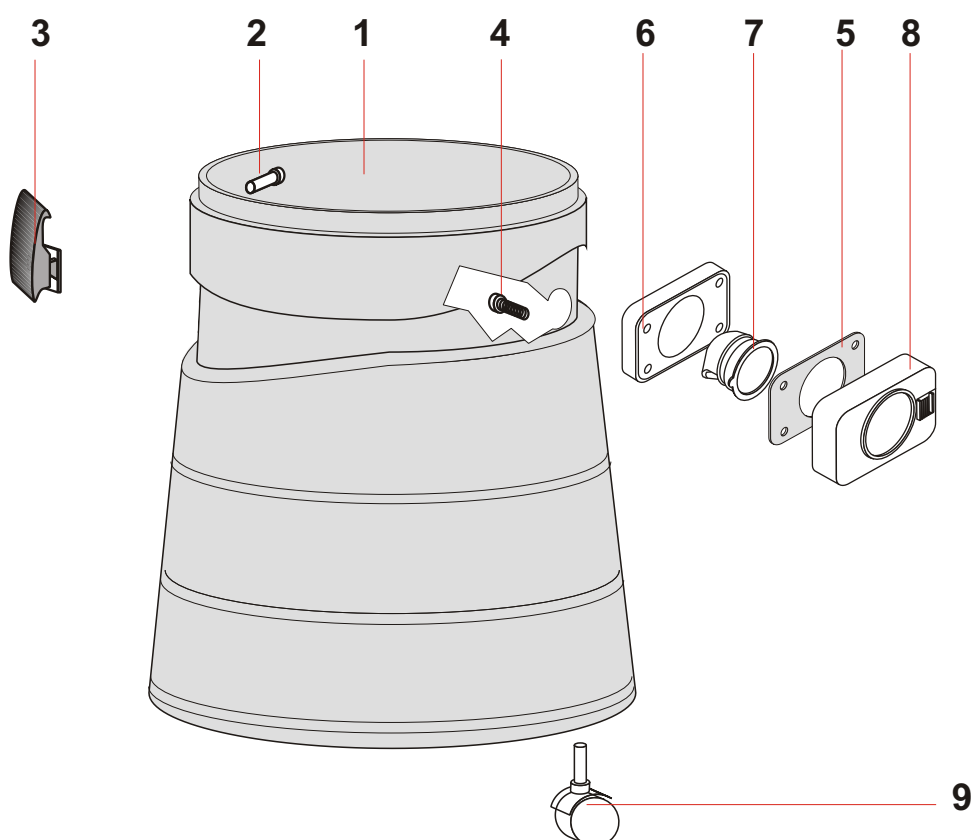
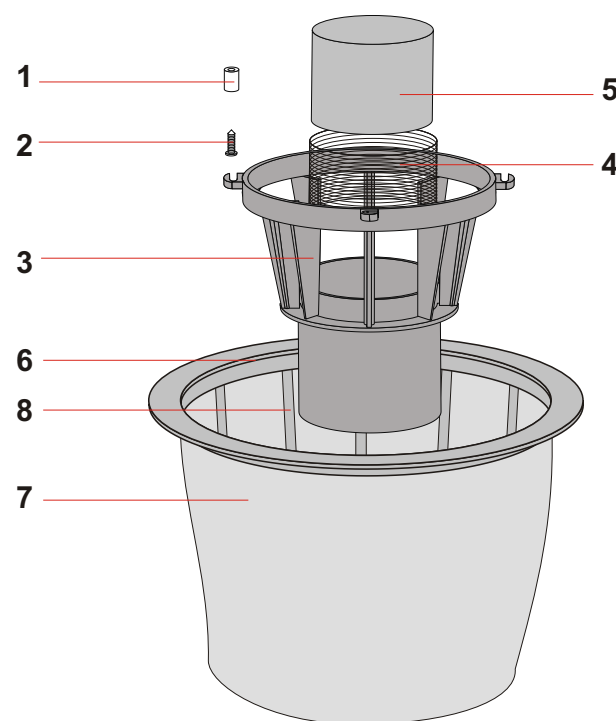

FUSTO PLAST/GRANDE V/INOX COMP.		REF. 2668/K	
POS	REF.	DESCRIZIONE	N°
1	2599	FUSTO PLAST/GRANDE	1
2	1300	RIVETTO 5X24,5	4
3	1847/S	GANCIO PLASTICA COMPLETO	2
4	6258	VITE AUT. TC PHL 4,8X32 INOX	4
5	2846	GUARNIZIONE Ø 38	1
6	2586	GUARNIZIONE R 205	1
7	2593	DEFLETTORE 99	1
8	2652 A	BOCCHETTONE R155	1
9	558	RUOTA CARRELLO BOX	6